

LP6.1 Turntable

USER GUIDE

Congratulations on your new CONSONANCE!

Opera Audio products are based on a simple philosophy:

The component shall reproduce the original musical sound, purely and naturally.

The products are easy to operate and are manufactured according to the best quality principles.

All CONSONANCE products are created with acoustical instruments in a concert situation as point of reference. The music is reproduced exactly like the original and is limited only by the quality of the recording.

Our aim is to give you the best possible music experience!

CONTENTS

Partlist p.1

Assembling the Turntable p.2

Technical specifications p.5

Use & Placement p.5

Cleaning p.5

Note & Warning p.6

Warranty p.7

Partlist

1. Platter

2. Plinth

3. Strobe disc

4. Record mat

5. Lubrication oil

6. 5mm allen wrench

7. Belt

8. T988 tone-arm

9. Power supply socket

10. Speed adjustment POT

11. On-off switch

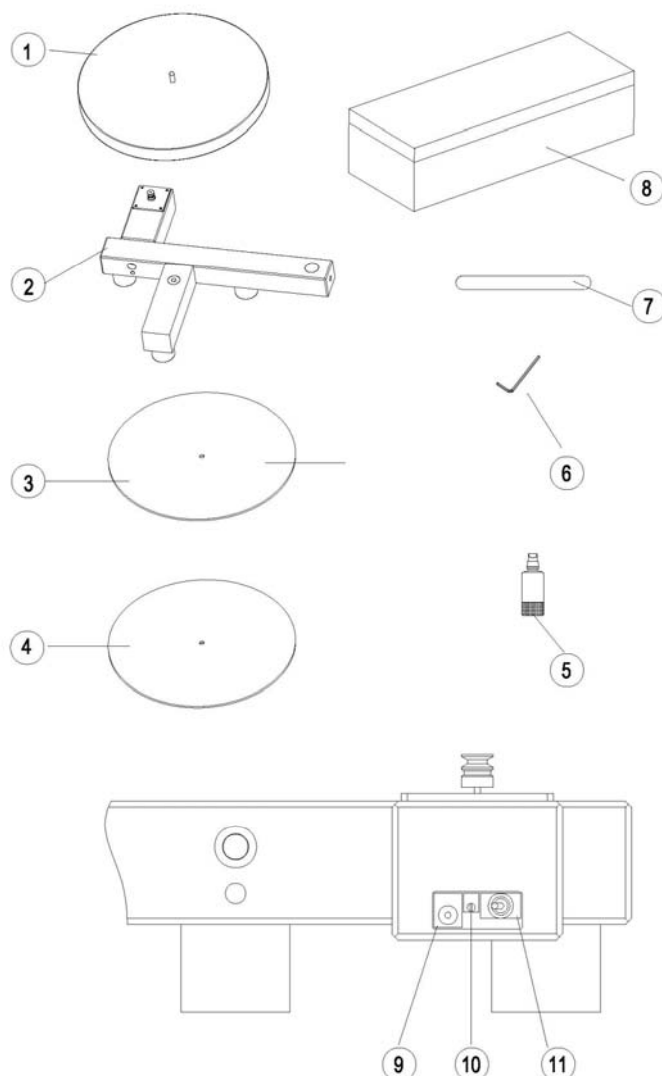

Assembling the Turntable

1. Take out the plinth.

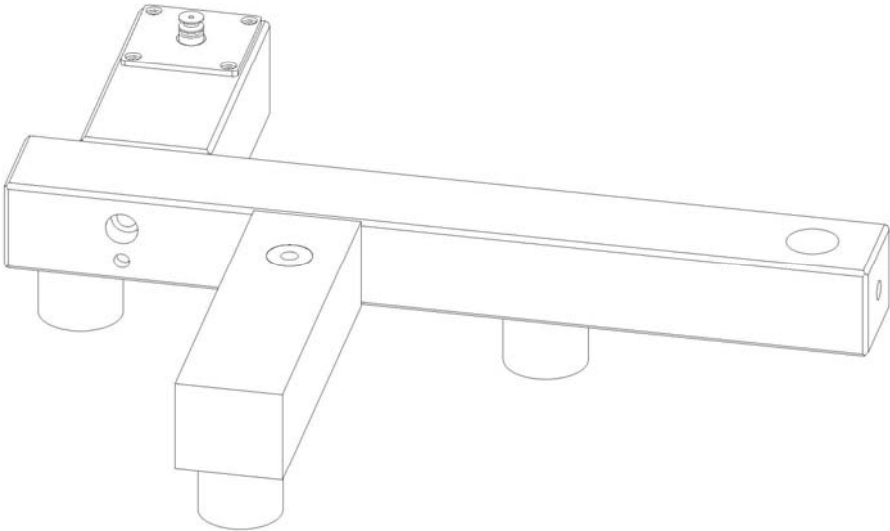

2. Fill the bearing with lubrication oil supplied to a level of approx 1mm above the bottom bearing.

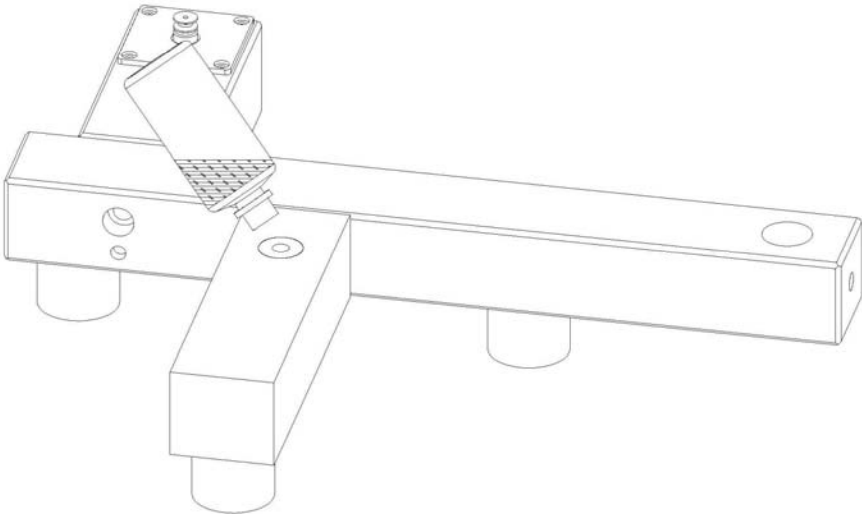

3. Installing the platter. Put on the cotton gloves and pick up the acrylic platter. Hold it level over the bearing housing, locate it carefully and gently lower it until it seats fully over the bearing.

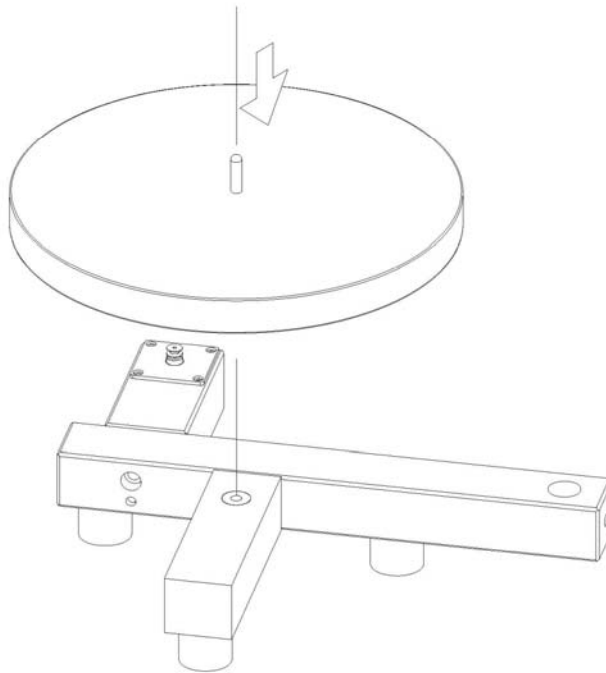

4. Installing the belt. Start with the belt around the motor pulley, take care the other end clears the centre spindle and rotate the platter, the belt will track around the platter.

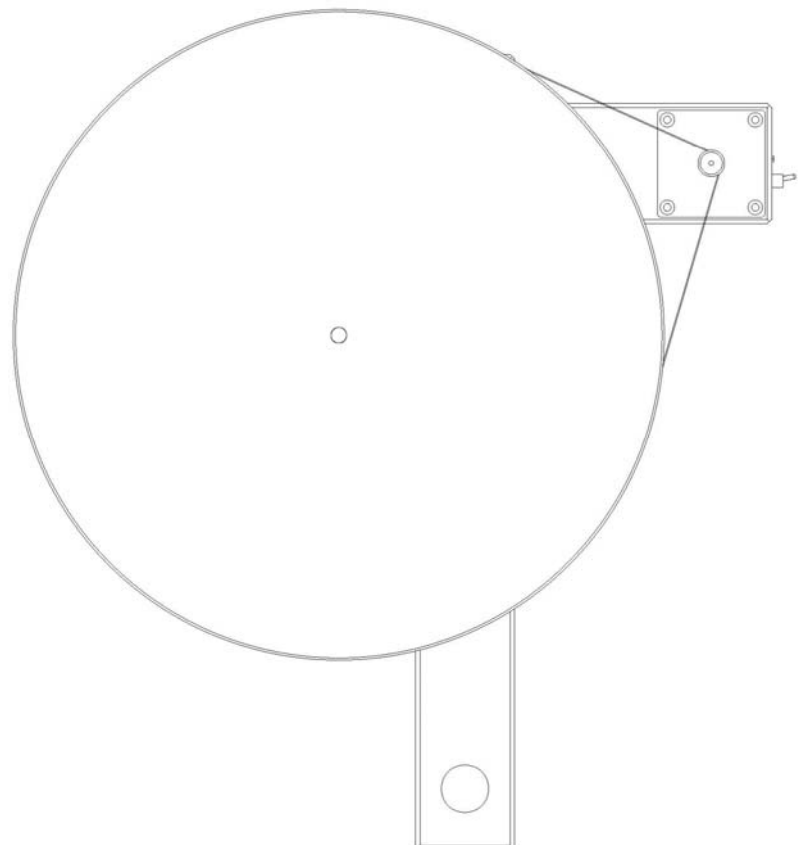

4. There are two ruts on the pulley of motor. The above rut is for 33.3 rpm, and the other rut is for 45 rpm. Different ruts for the different speed.

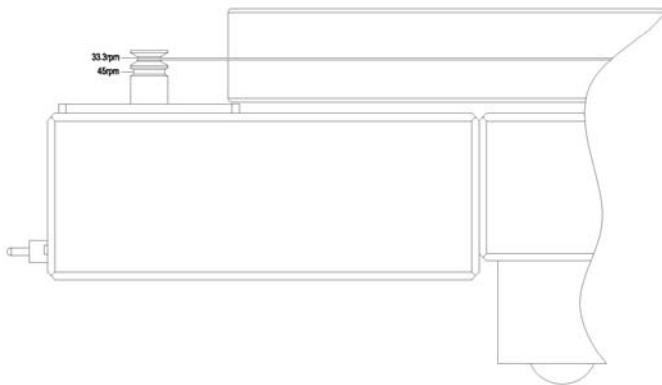

5. Fitting the cartridge and tonearm adjustments. Please take tonearm manual as reference. The tonearm VTA adjustment should be according to the pictures below.

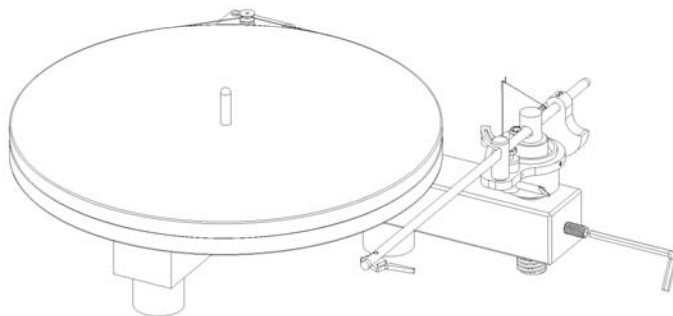

If you want to use 12" tonearm, you can buy T1288 extra armshaft. Then replacement the plinth according to the pictures below.

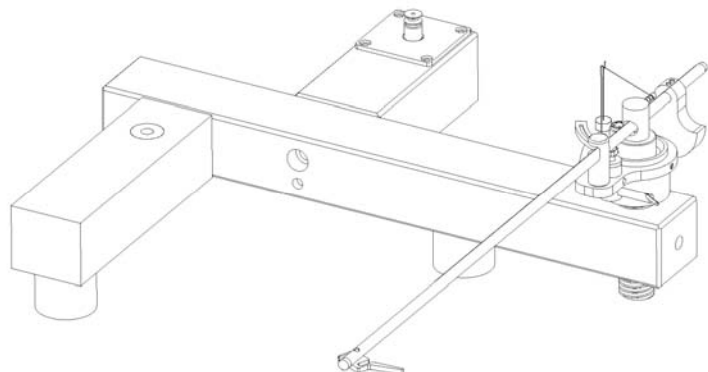

⑩ is for tiny speed adjustment. If the speed has small distinction, you can use strobe disc to test and adjust ⑩.

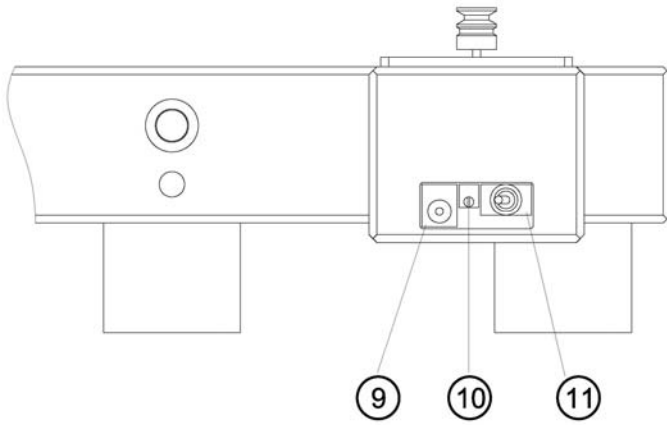

Motor power supply use DC 12V.

TECHNICAL SPECIFICATION

Wow and Flutter: Less than 0.03

Rumble: Greater than 80dB down

Speed accuracy: Within 0.01%

Motor power : DC 12V

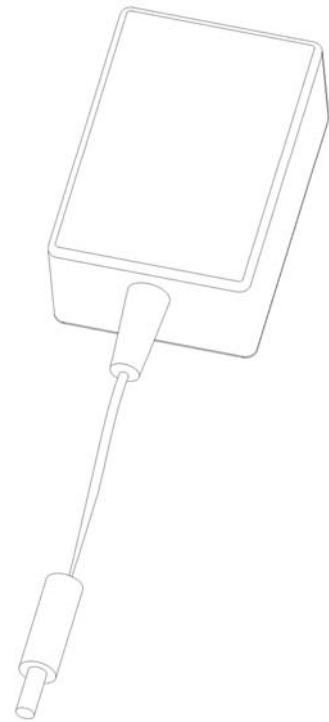

USE & PLACEMENT

The Consonance LP6.1 should be placed on a flat, hard surface for proper standing. The turntable performs best after being switched on for 5 minutes for running smooth. A certain space is required for tonearm moving above the turntable on the right side. The turntable must never be placed on a soft or unstable base. Nor must it be covered while in use or placed on a narrow shelf or in another confined space.

CLEANING

The base of the turntable and turnarm as well as the motor are made of solid, powder coated aluminum. Fingerprints can be removed with a cloth moistened with warm water. A silk cover would be the best keeping dust away from the whole LP system.

NOTE & WARNING

Opening of the product by non-authorized personnel will void the guarantee.

The products must not be exposed to rain or moisture.

Motor should only be opened or serviced by certified technicians. The devices contain electronic components that can cause severe electric shock. Work performed on Consonance products by unqualified personnel can cause serious damage and personal injury.

WARRANTY

Opera audio guarantees each product manufactured by us to be free from defects in materials and workmanship under normal use. Our obligation under this warranty is limited to making good at our factory any part or parts thereof which shall, within 1 year after delivery to the original purchaser, be returned to us with transportation charges prepaid, and which an examination shall disclose to have been thus defective; this warranty being expressly in lieu of all other warranties expressed or implied and of all other obligations or liabilities on our part. This warranty shall not apply to any Opera audio product which shall have been repaired or altered outside of our factory in any way so as to affect its stability, nor which has been subject to misuse, negligence or accident. Warranties of the vacuum tubes are by the respective manufacturers, usually 90 days.

Please mail or e-mail the Registration Card to the address as follows:

The Opera Audio Co., Ltd.

No.2 JianXianQiaoLu

ChaoYang District

Beijing, China

Tel: 86 10 59789461

Fax: 86 10 59789465

support@opera-consonance.com

www.opera-consonance.com



Registration Card

Name
Address

City
State
Zip
Email
Telephone
Model
Serial Number
Purchase Date
Dealer