

Trio tonearm

Package contents

The **consonance Trio** tonearm is packaged in special designed box to ensure it safety on the way. Please check the diagram in below picture and in the part list description:

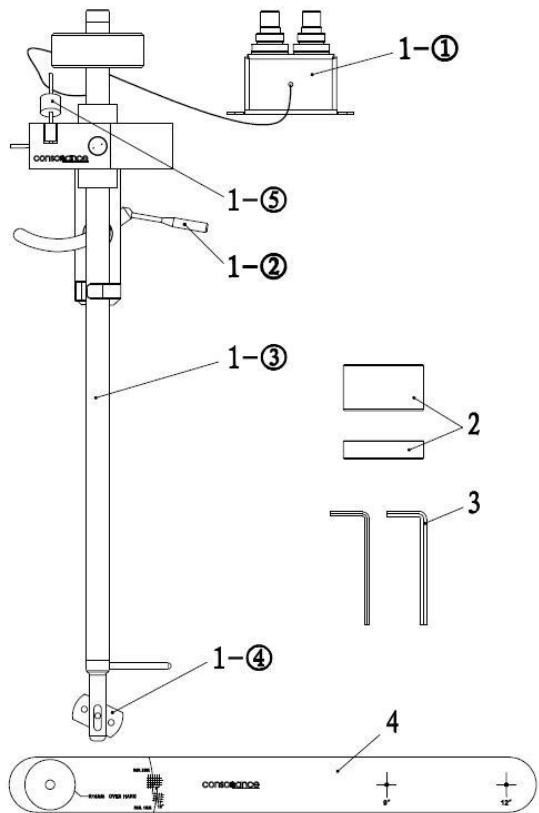

- 1-① . RCA connector
- 1-② . arm lift
- 1-③ . Aluminium tube
- 1-④ . Headshell
- 1-⑤ . Anti-skate weight
- 2 . Counterweight
- 3 . Allen wrench
- 4 . Protractor

TECHNICAL SPECIFICATION

Mounting distance arm base	290mm
Tone arm length	12"
Overhang	16mm
Offset	17 degree
Cartridge weight	4-22g
Mass (without counterweight)	68g
Counterweight	65g/18g